

Panel construction

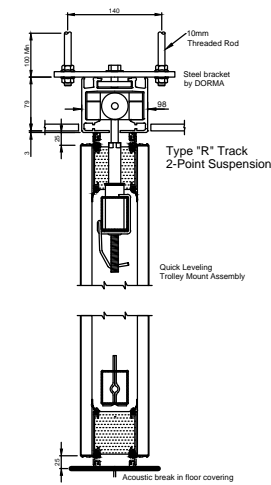

Standard panel joint

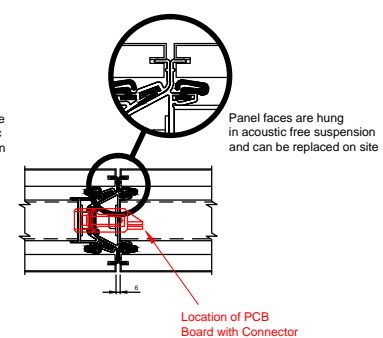
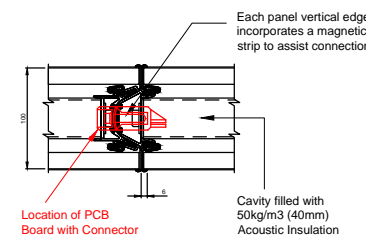
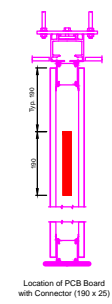

Type "U" Protective Vertical Frame

Type "K" Concealed Vertical Frame



DORMA Movable Walls Pty Ltd  
Web site: www.dorma.com.au

PROJECT NUMBER:

PROJECT NAME:

TITLE: HEAD & PANEL DETAILS

PRODUCT: VARIFLEX 100SA

DRAWING NUMBER: D3	SCALE NTS	REVISION
-----------------------	--------------	----------

Approx. 100mm thick panels

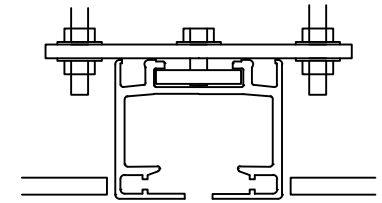

HEAD TRACK

DRAWN BY (PRINT & SIGN): MA	DATE: 06/09/2013
--------------------------------	---------------------

APPROVED BY: \_\_\_\_\_

DATE: \_\_\_\_\_

Typical configurations (Telescopic Closure)

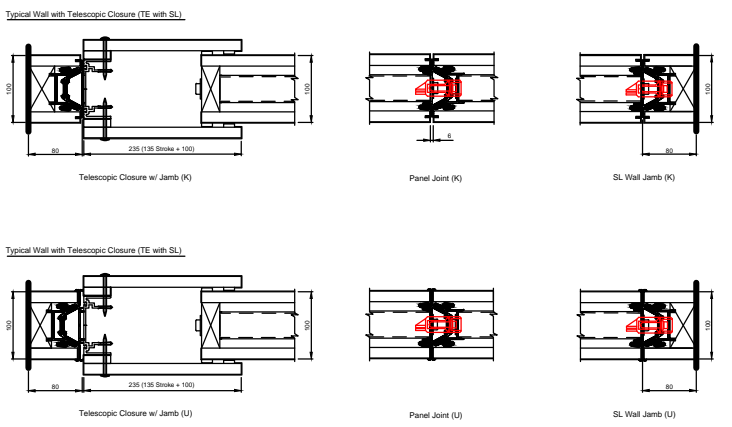

Typical configurations (Full height pass Door Closure)

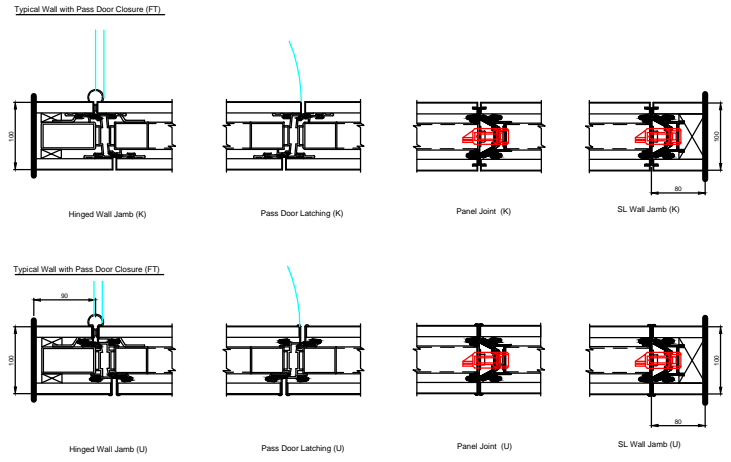

Wiring Diagrams

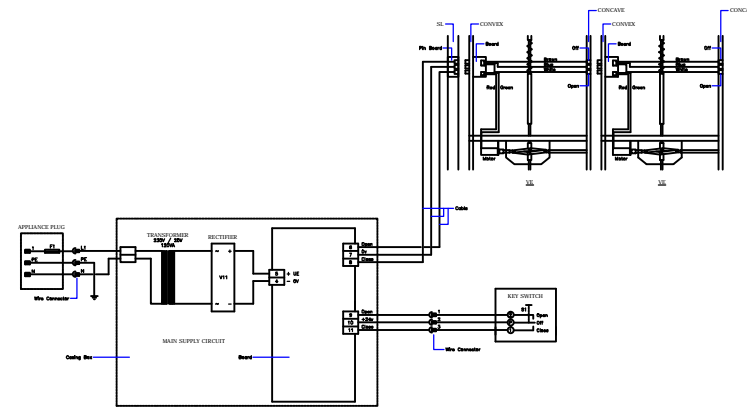

Inset pass through doors (Door within a panel)

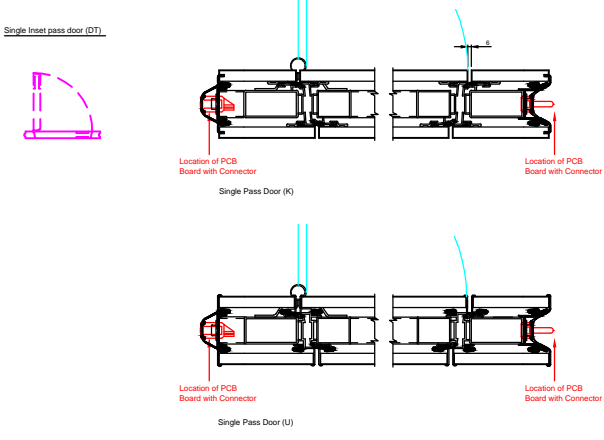

Double inset pass through doors

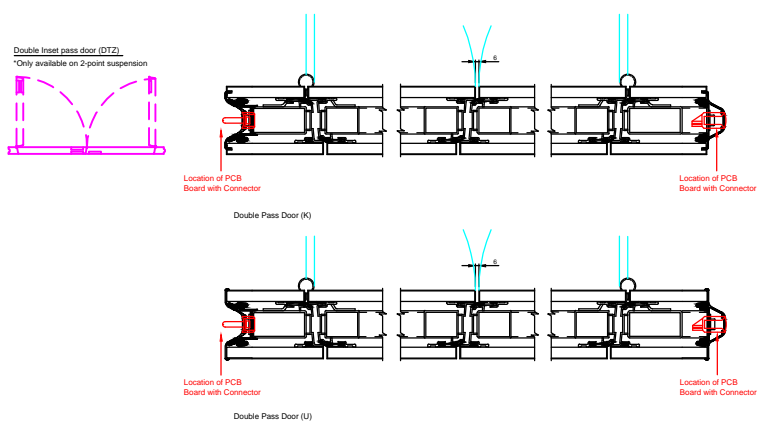

Windows

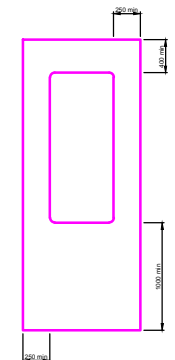
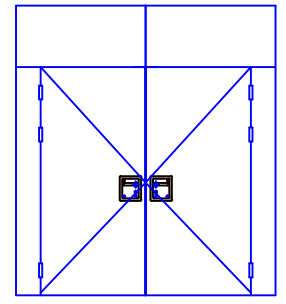
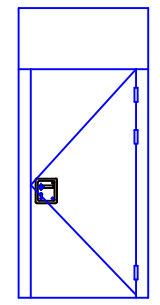
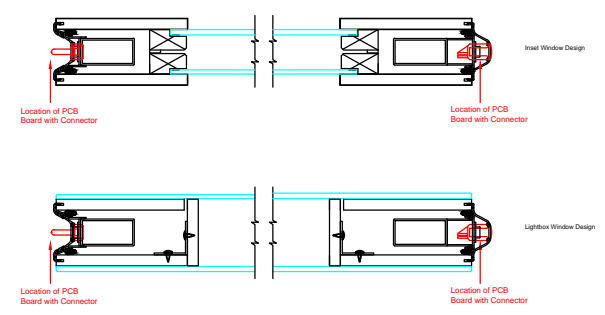

No	REVISION	DATE
A		
B		
C		
D		
E		